



ENGINEERED PRODUCTS

**PUNCHING SHEAR REINFORCEMENT
SHEAR STUD RAILS**



**MAKING
THE
COMPLEX
SIMPLE**



PUNCHING SHEAR REINFORCEMENT

Punching shear is a type of failure of reinforced concrete slabs subjected to high localised forces. In flat slab structures, this most commonly occurs at column support points. The failure is due to shear is critical because no visible signs are shown prior to failure.

Commonly, punching shear is solved using a downstand in a slab, increasing the localised thickness of the slab and reducing chance of punching shear. Or otherwise, the stirrups are installed around the column to relieve punching shear. SRG shear stud rails are installed with-in a flat slab to strengthen the reinforcement around a column and solve the issue of punching shear through engineered design.

Strengthening slabs with punching shear reinforcement such as shear stud rails is a fast and economical solution for the problem. SRG Global's range of shear stud rails are bespoke to customer requirements and are manufactured in Australia to comply with Australian Standards.

Example of Failure due to punching shear



SRG Global's Shear Stud Rails

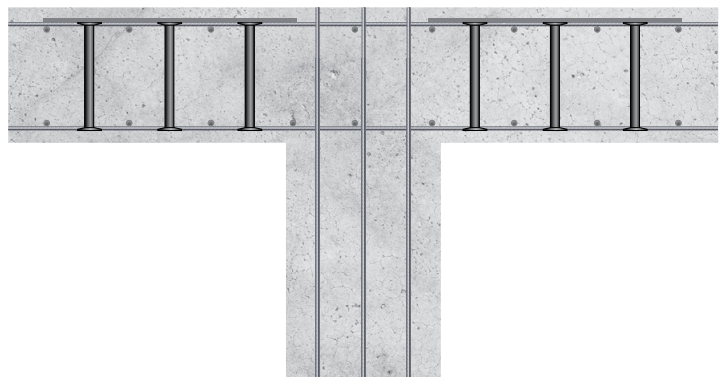



Shear Stud Rails

SRG Global's Shear Stud Rails comprise of double headed forged steel studs welded to rails possessing a minimum yield strength of 500 MPa. These rails provide punching shear reinforcement to the slab as it increases the area that is responsible for transferring vertical loads to the column. This localised reinforcement ensures thin slabs can be utilised without being governed by punching shear issues.



Benefits

- High slip resistance (load bearing capacity).
- Static & Dynamic Loads that are also compliant with BS EN 1992-1-1 (Eurocode 2), BS 8110-1 and AS 3600-2018.
- Combination of standard sized units meets the demand.
- Eliminates column caps.
- Higher shear capacity than stirrups which are labour intensive to assemble on site and create heavy congestion of reinforcement.
- Simple and fast installation on site.
- Engineered product with accurate punching shear capacity.
- Studs tested for tensile capacity.
- Allows for faster floor to floor cycles.
- Full take-off and scheduling services included.

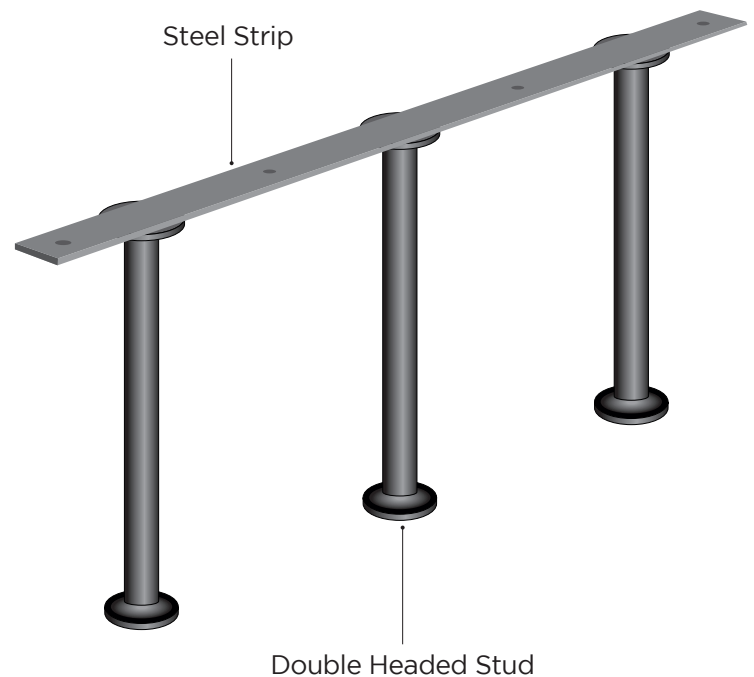



SPECIFICATIONS

SRG Global offers four diameters of studs, 12mm, 16mm, 20mm, and 24mm. All Studs are hot forged 3 times (3 x d) its diameter and heat treated to 500 MPa Yield strength. The table below outlines standard Stud Diameter and measurements. Stud Height is Bespoke to requirement and custom sizing of all lengths can be feasibly manufactured.

Stud Dia. ϕd	Head Dia. ϕD	Head Thickness	Stud Cross Section	Head Cross Section	Characteristic Yield Strength
mm	mm	mm	mm ²	mm ²	MPa
12	36	6	13	1018	500
16	48	8	201	1810	
20	60	10	314	2827	
24	72	12	452	4072	

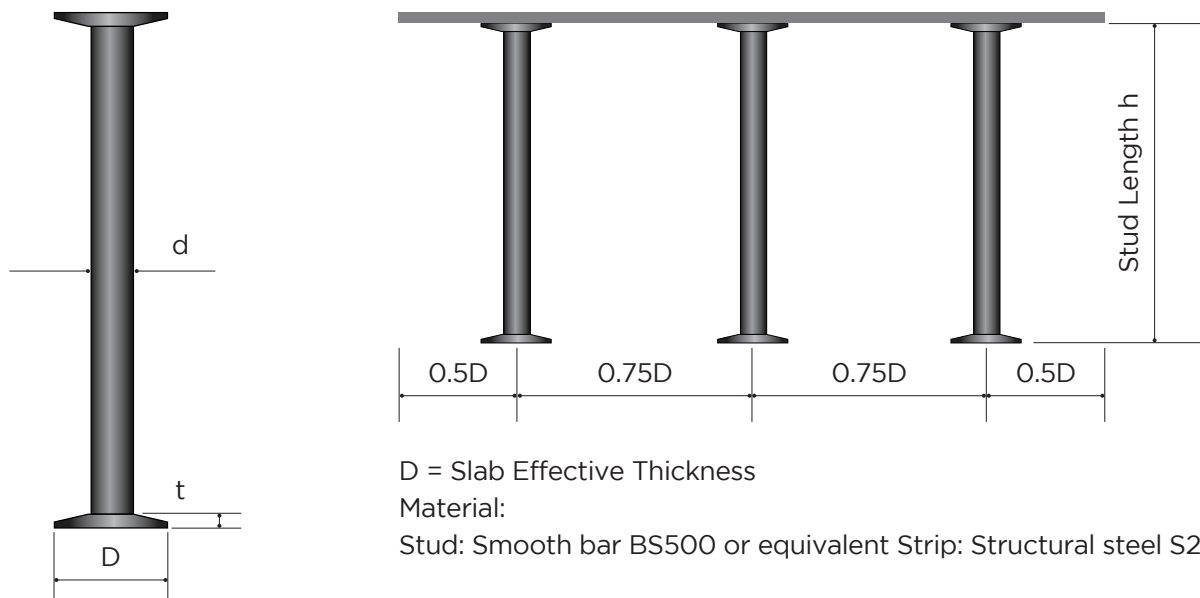

The heads of SRG punching shear studs are hot-forged to 3 times the diameter of the shaft, to ensure the best performance of the slip resistance in accordance with BS EN 1992-1-1, BS8110-1 and AS3600-2018, the material of the stud is smooth bar BS500 or equivalent. The double-headed studs are welded onto the steel rail at the required spacings determined by the consultant's design. The steel rail possesses no structural role, its purpose is purely to facilitate the desired stud arrangement within the slab.



Product Identification

SRG Global Shear Stud Rails follow a stringent naming convention to provide ease of understanding for both the customer and manufacturing purposes. Overall, the determining design factors of Shear stud rails include *Stud Diameter*, *Stud Height*, *Spacings*, and *Rail Length*. SRG also ask for distance to first and distance to last stud to be provided for our convenience. Each Stud rail carries the following naming convention:

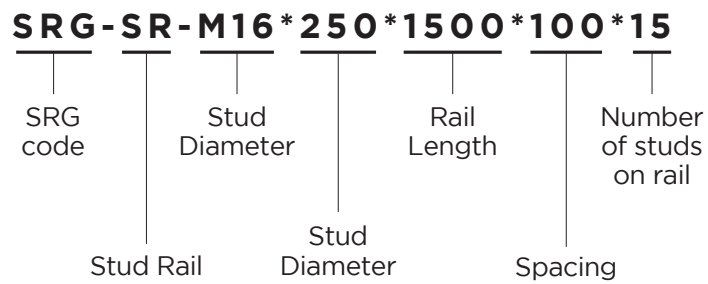

Order from SRG

To place an order for Shear Stud Rails please email your relevant states sales manager with desired stud diameter, stud height, spacing, and rail length. Or alternatively take advantage of our project specific management, and email a tender package to us.

Mark	Location	Number of Studs Per Rail	Stud Diameter (mm)	Stud Height (mm)	Rail Length (mm)	Stud Spacing (mm)	Distance to First/Last Stud (mm)	Total Quantity of Rails



DESIGN METHOD

Calculation Method

Punching shear is not directly accounted for in Australian Standards, however SRG Global Shear Stud Rails are designed to meet AS 3600:2018, referencing Section 9 Clause 3; “*Strength of Slabs in Shear*” in tandem with the Lim & Rangan study (1995). The research work on shear stud rails undertaken by Lim & Rangan, has been used as the design approach for punching shear universally in Australia, and outline the critical requirement to be a minimum of 500Mpa Yield stress in the stud, to which SRG Stud rails meet, with appropriate NATA certification. The calculation method outlined below is set out to design the shear stresses imposed on the critical shear perimeter around a column and inside a flat slab, to be able to provide the right amount of shear reinforcement.

Critical Shear Perimeter

To check shear capacities, design shear force V^* and design bending moments M^* of a slab should be considered. It is also important to understand the concepts of Critical Shear Perimeter and Critical Opening.

Critical Shear Perimeter, u_o is the defined boundary of the effective area around the column and is where shear failure will occur. Taken as the perimeter $d/2$ around the column (where d is the slab thickness). Any opening, or otherwise a Penetration, through a slab where the edge is less than $2.5b_o$ away from the critical shear perimeter, is known as the critical opening (where b_o is the width of the penetration). The critical opening forms a projected cone of ineffective area which would require extra consideration for stud rail requirements. See figure below.

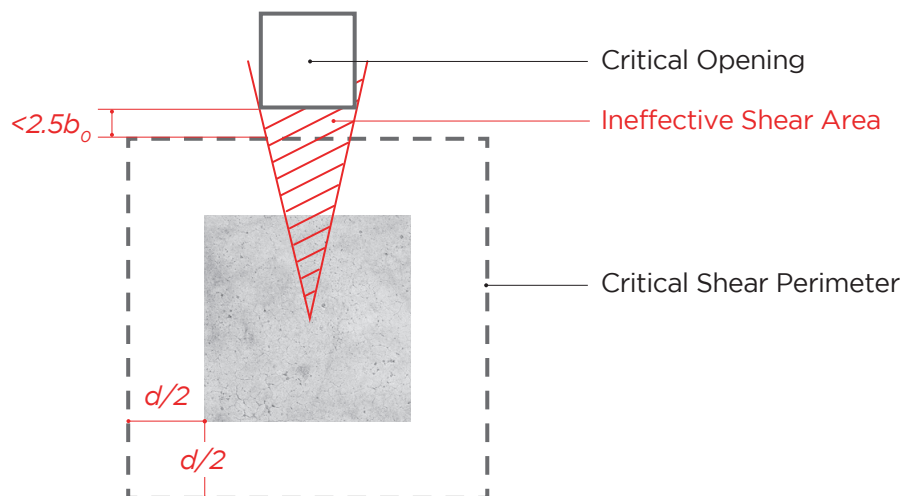



Shear Stress

Where shear failure would occur at an area of concentrated load or around a support (typically a column) the design shear strength is taken as ϕV_u , where V_u is found through two different cases according to AS3600 Clause 9.3.3 and 9.3.4. Once found, if the below equation is not satisfied, the area will require punching shear reinforcement.

$$V^* \geq \phi V_u$$

If Shear force is greater than the ultimate shear strength, Stud rails are required!

Design Detailing

In columns requiring shear reinforcement, refer to the Lim & Rangan (1995) research, which detail equations and research recommendations for the design of suitable shear stud rails.

Typically, it is recommended to allow $0.75D$ (where D is the effective slab thickness) for spacings of shear studs and allowing stud height to be dictated by desired concrete cover. (Typically, 20mm top and bottom).

In order to determine rail length and number of studs, continue adding additional studs until shear stress at the critical shear perimeter is less than the shear capacity of 500MPa. This is to be done in accordance with the Lim & Rangan design recommendations.

TYPICAL ARRANGEMENTS

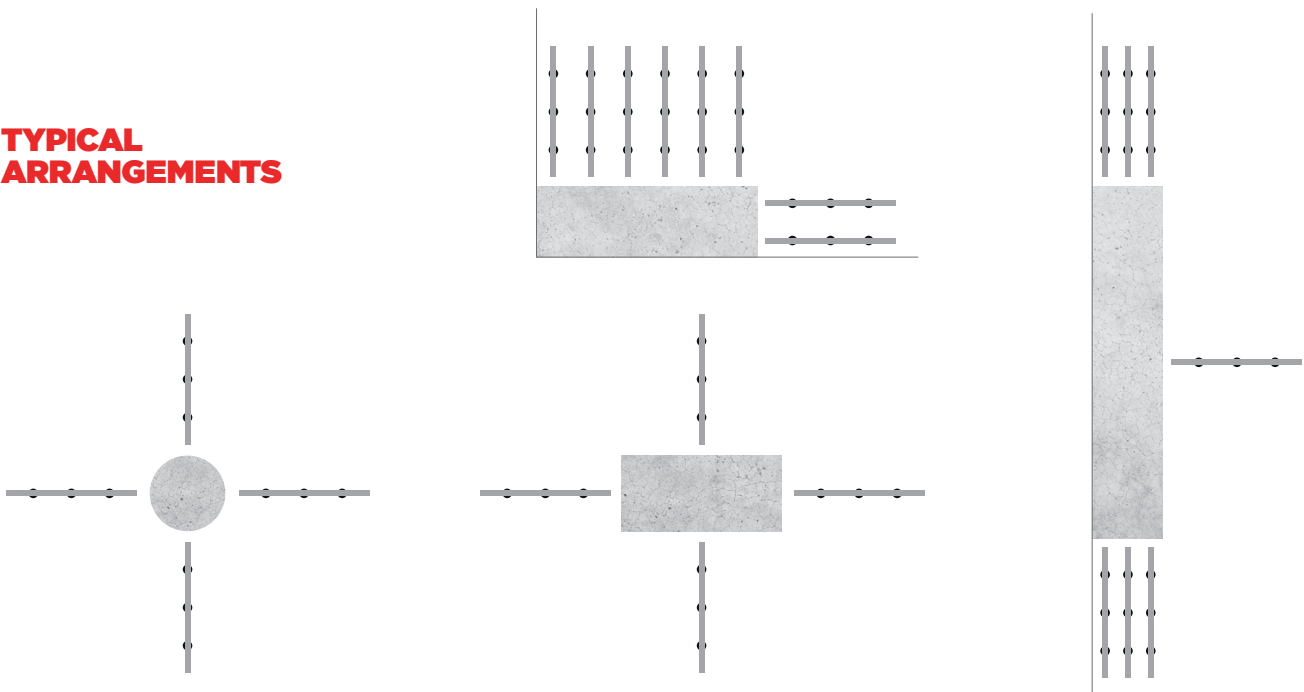



srgglobal.com.au

CORPORATE HEAD OFFICE

Level 2, 500 Hay Street,
Subiaco, Western Australia 6008

+61 8 9267 5400

Info@srgglobal.com.au

QLD

42 Robson Street,
Clontarf, QLD 4019
+61 7 3888 6655

WA

5 Riversdale Road,
Welshpool, WA 6106
+61 8 9267 5400

VIC

2/290 Salmon Street,
Port Melbourne, VIC 3207
+61 3 9296 8100

NSW

Unit 2B/149 McCredie Road,
Smithfield, NSW 2164
+61 2 8767 6200